

Bundle DuraMulti DI 12x5/3,5 mm LSHF

Bundle DuraMulti DI LSHF is intended for protection of optical microcables. It is used mainly in places where reduced flammability is required. The bundle is self extinguishing and formation of smoke is reduced during combustion (LS=Low Smoke). Microducts DuraMicro DI LSHF are oversheathed by foil from compound of polyethylene and halogen free (HF) flame retardants. Access to microducts is easy because of thin sheath, which is not attached to microducts.

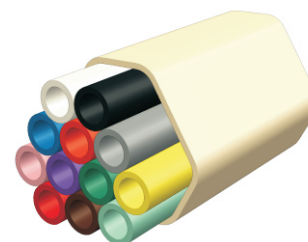
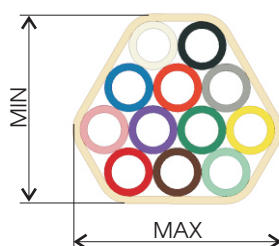

Wall thickness of microducts, bundle sheath and type of material classify the bundle as a Direct Install (DI) for installation to places with additional mechanical protection. Installation methods and conditions are described in the Installation manual.

The quality management system of Dura-Line CT is certified acc. to EN ISO 9001. Bundle does not contain dangerous chemicals in accordance to the Directive 2006/1907/EC (REACH). Bundle meets requirements of the Directive 2002/95/EC (RoHS) - content of lead, cadmium, mercury, Cr^{VI}, PBB and PBDE.

Parameters of microducts are in relevant Technical Data Sheet and in company standard CWS104-03.

Parameter	Value
Maximal dimension of cross section (MAX)	*21,5 mm
Minimal dimension of cross section (MIN)	*20 mm
Sheath thickness	*0,75 mm
Weight	*182 kg/km
Transport and storage temperatures	from -40°C to +70°C
Installation temperatures	from -10°C to +50°C
Operating temperatures	from -40°C to +70°C
Installation tensile force	max. 1 200 N
Min. bending radius	200 mm
Outdoor exposure limit in Central Europe	max. 12 months

* informative value

- **UV stabilized** is more resistant to ultraviolet radiation. Storability is prolonged to 24 months at Central Europe outdoor conditions. Microducts and sheath are stabilized.
- **Antistat** - lower electrical surface resistance. Microducts and sheath are antistatic.

Bundle is supplied in natural white version or in a wide scale of the following RAL list.



DESCRIPTION, APPLICATION

LEGISLATION

PARAMETERS

MODIFICATION

COLOR LIST

MARKING

Bundle DuraMulti DI 12x5/3,5 mm LSHF

Bundle is printed in whole length according to customer requirement. Printing color is contrasting to bundle color. Printing can be doubled in opposite sides as an option. Printing scheme is repeating after 1 metre.

Example of printing scheme:

DURA-LINE CT DuraMulti DI 12x5/3,5mm LSHF SILICORE 03/2009 LOT No 12345678 0000 m ><

PACKING AND STORAGE

Bundle is wound on disposable drum (MTB) and coil is wrapped by stretch film. Bundle's ends are protected by plastic caps protecting them from impurities penetrating into microducts. End of bundle is minimally 10 mm under the flange edge. MTB flanges are regularly made from chipboard and have to be protected from moisture.

Option - MTB flanges can be made from Oriented Strand Board (OSB) which is waterproof.

MTB core diameter is 415 mm.

All drum dimensions are informative values.

Drum width is measured near center in place of axis. The periphery width can be higher up to 10% because of pressure winded bundle.

Other types and dimensions of drum are on request.

Drum	Flange diameter (mm)	Drum width (mm)	Shaft hole diameter (mm)	Winding maximum length (m)	Informative weight of full drum with chipboard flanges (kg)
MTB3	900	640	65	500	110
MTB8	1 030	640	65	800	170
MTB16	1 250	740	65	1 600	320

MTB3

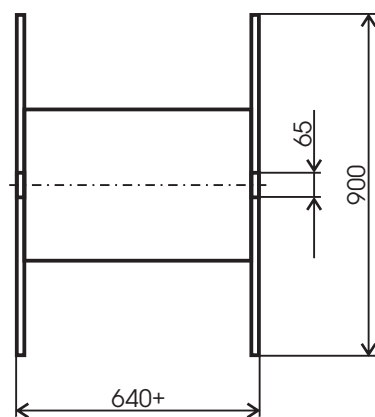

MTB8

